

SC5745 Main Body

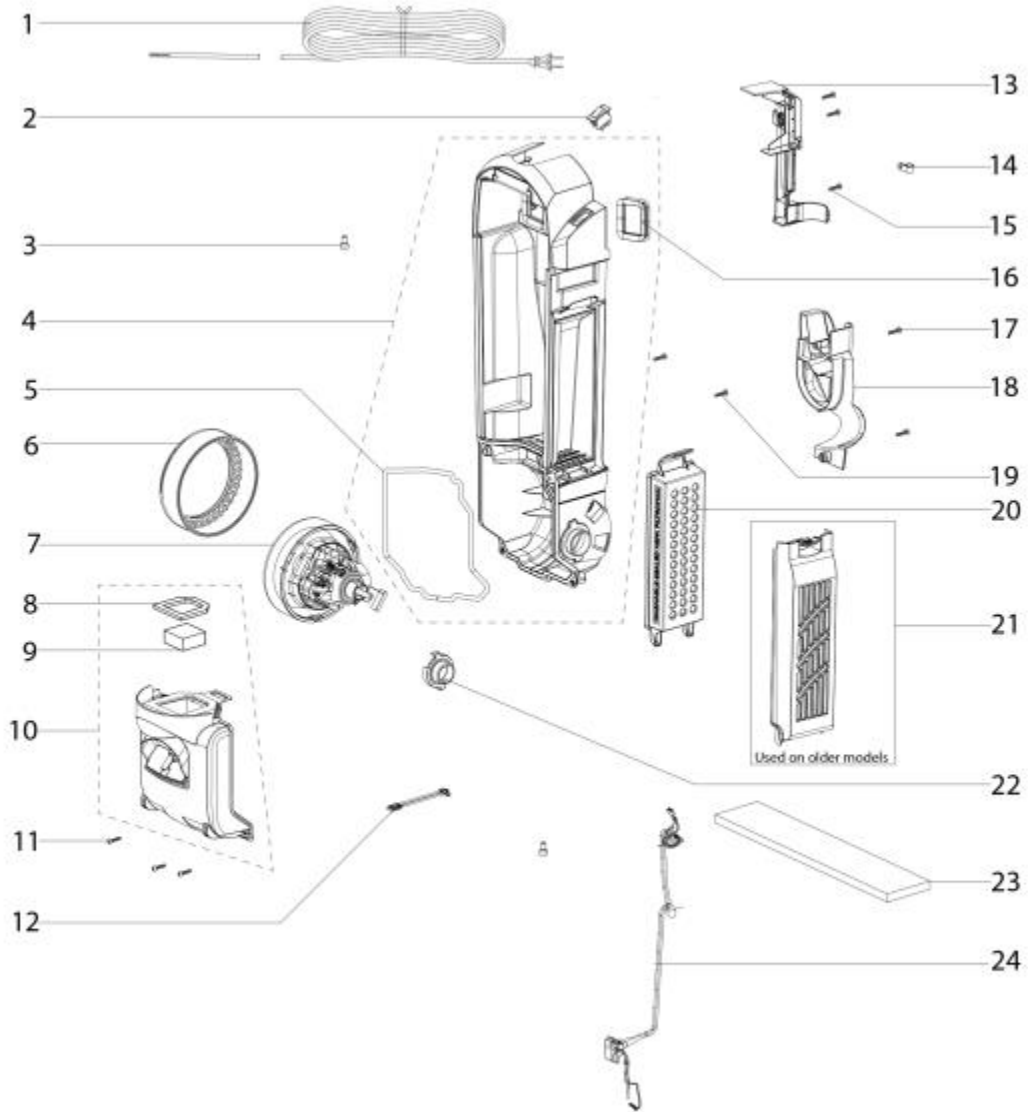

MAIN BODY - SC5745A

Ref #	Part	Description	Comments	Qty
1	38680-32	SUPPLY CORD & TERMINAL AS		
2	28073A	SWITCH - ROCKER		
3	60192-1	WIRE SPLICE 5		
4	72126B-1	REAR HOUSING ASSEMBLY	Includes items 18 & 25	
5	71484	Gasket - Motor Cover (NLA)		
6	75348	GASKET - MOTOR CAN		
7	62394-1	MOTOR ASSEMBLY - PACKAGED		
8	71483	GASKET - DIRT CUP LOWER		
9	71480	FILTER - PRE-MOTOR		
10	61863-23	MOTOR COVER ASSY - PACKAG	Includes items 7 & 8	
11	53238-27	SCREW PACKAGE		
12	59213-7	THERMOSTAT 110 DEG		
13	72127-1	SWITCH COVER ASSEMBLY		
14	63234	CABLE CLAMP - PACKAGED		
15	53238-27	SCREW PACKAGE	Pkg of 10	
16	71482	GASKET - INTAKE		
17	53238-27	SCREW PACKAGE	Pkg of 10	
18	71455-119N	TOOL PACK - LOWER		
19	53238-27	SCREW PACKAGE	Pkg of 10	
20	61840	WASHABLE HEPA FILTER - PK		
21	72006-16	FILTER COVER & GRAPHICS A		
22	75100A	BUSHING - MOTOR SUPPORT		
23	72224-1	FOAM - SOUND		
24	71465-3	CORD - JUMPER		

SC5745 Handle & Dust Cup

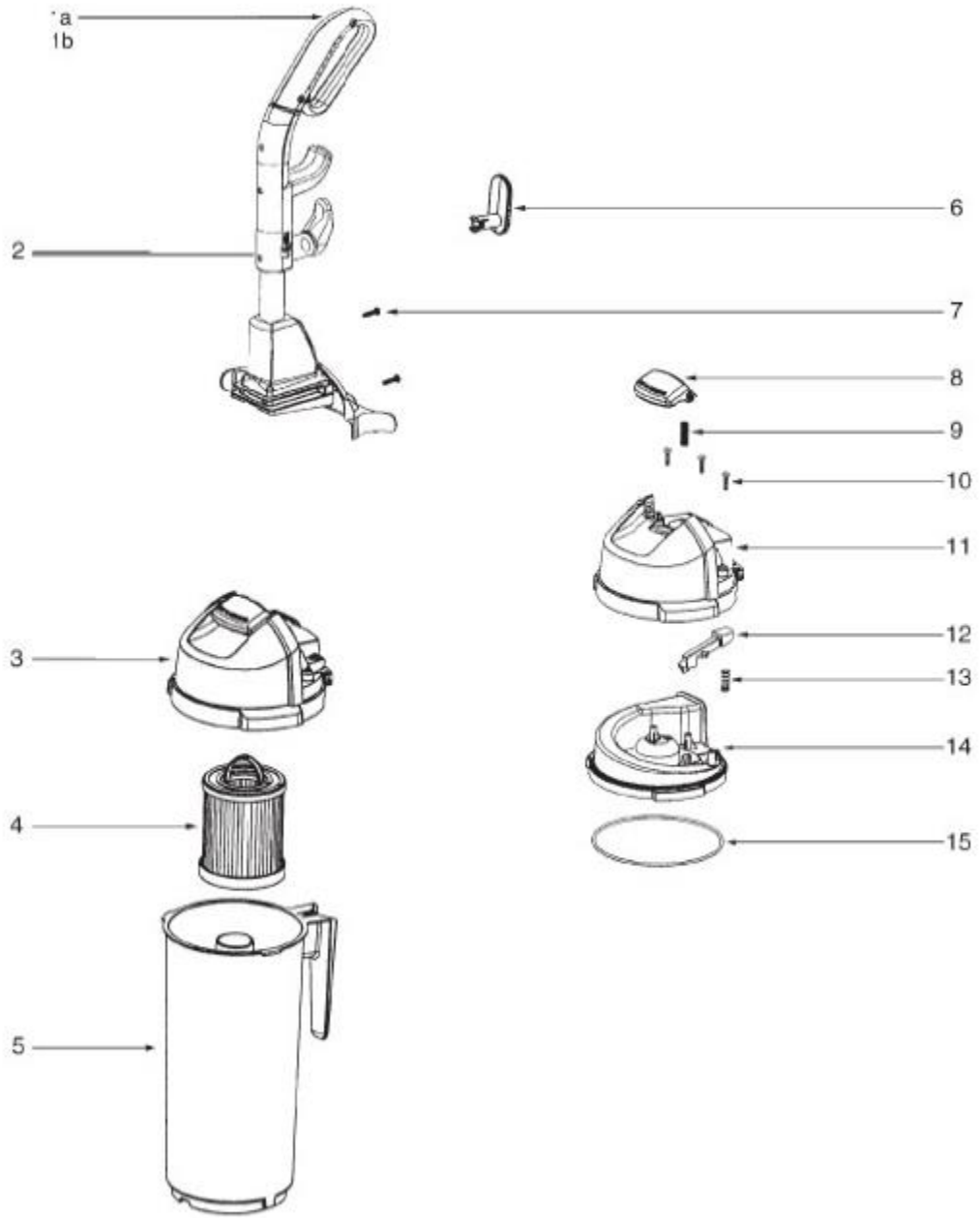

HANDLE & DUST CUP - SC5745A

Ref #	Part	Description	Comments	Qty
1a	15596-308N	GRIP - LEFT HANDLE		
1b	15597-308N	GRIP - RIGHT HANDLE		
4	71738A-4	DUST CUP FILTER ASSEMBLY		
5	61864-2	DUST CUP ASSY - PKGD		
6	28316-308N	RETAINER - CORD (QUICK RE		
7	54669-5	SCREW PACKAGE	Pkg of 10	
8	71479-308N	LATCH - DUST CUP		
9	61866	SPRINGS (NLA)	Pkg of 5	
10	53238-27	SCREW PACKAGE	Pkg of 10	
12	71785-119N	CATCH - FILTER IN PLACE		
13	61867	SPRING PACKAGE		
14	71451-119N	CYCLONE		
15	71475	GASKET - CYCLONE		
2	73175-2SV	UPPER HANDLE ASSEMBLY		
3	71537-38	CYCLONE ASSEMBLY		

SC5745 Base & Hood

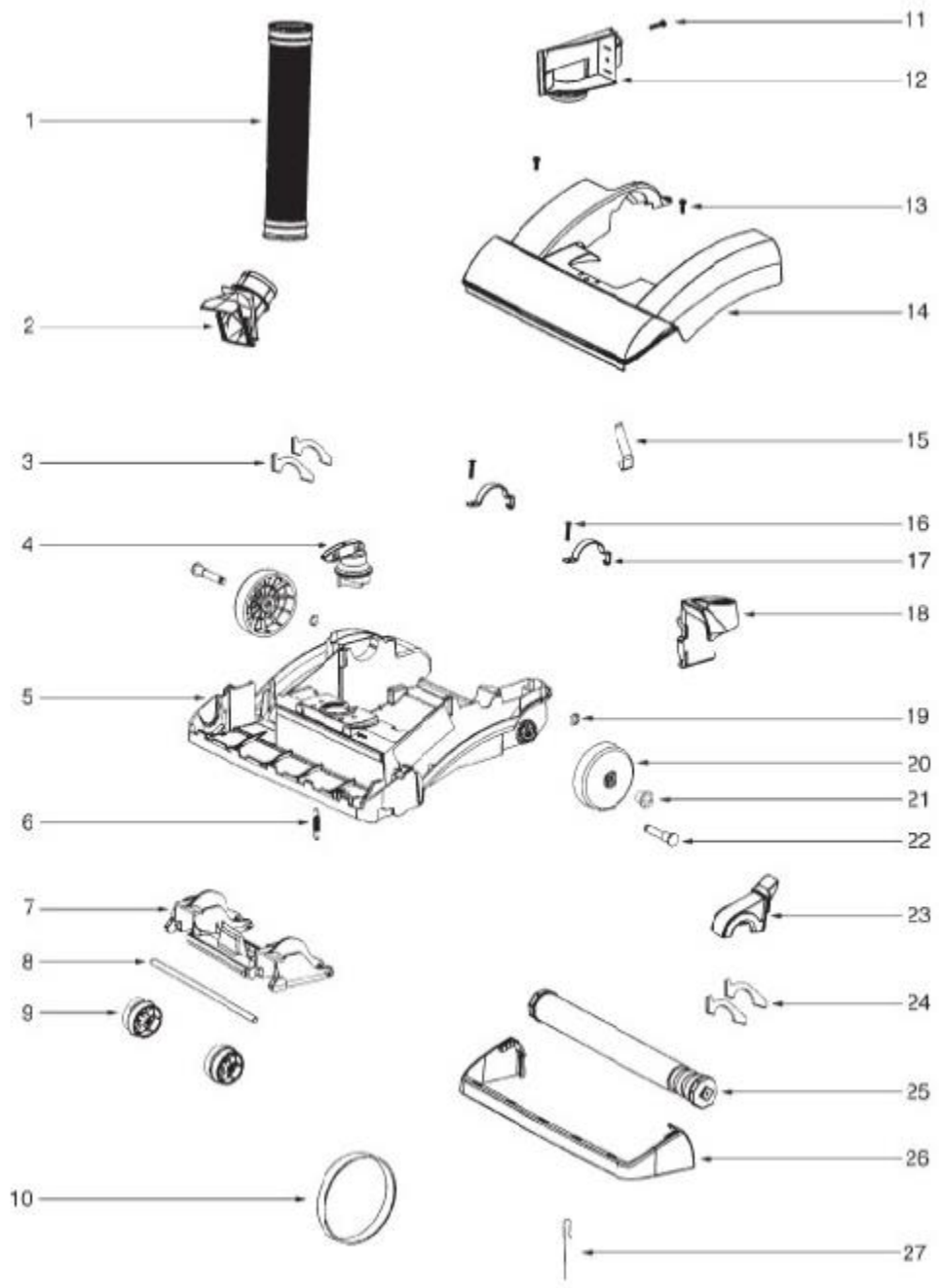

BASE AND HOOD - SC5745A

Ref #	Part	Description	Comments	Qty
1	71466	BASE HOSE ASSY		
2	71447-119N	BASE HOSE ASSY		
3	73153	FELT - BASE		
4	71448-308N	KNOB - HEIGHT ADJUSTMENT		
5	62411-2	BASE ASSEMBLY - PACKAGED	Includes items 3,4,6,7,8,9,15,18,19,20,21,22, 26 & 27	
6	54943	SPRING PACKAGE	Pkg of 10	
7	71446A-119N	CARRIAGE - WHEEL		
8	71478	AXLE - FRONT		
9	39173A-119N	WHEEL - FRONT		
10	61120A	BELT PKG ASSY-STYLE U EXT		
11	53238-27	SCREW PACKAGE	Pkg of 10	
12	71726-119N	BASE HOSE ASSY		
13	53238-44	SCREW PACKAGE	Pkg of 10	
14	62412-3	HOOD ASSEMBLY - PACKAGED		
15	71574	SPRING - HANDLE RELEASE		
16	53238-27	SCREW PACKAGE	Pkg of 10	
17	71487	CLAMP - MOTOR		
18	71457-355N	RELEASE - HANDLE		
19	54432-1	PACKAGE - RETAINING RING	Pkg of 10	
20	72512-1	REAR WHEEL ASSEMBLY		
21	73432	BUSHING-AXLE		
22	38590A	AXLE - REAR		
23	71741A	BELT CAP ASSEMBLY		
24	71672A	FELT - BELT CAP	Includes item 24	
25	60844-10	12" BRUSH ROLL		
26	71456-355N	FURNITURE GUARD (NLA)		
27	38063	GUARD - BELT		
	82558-316N	DAMPENER- END CAP (LH)		
	82559-316N	DAMPENER- END CAP (RH)		

SC5745 Accessories

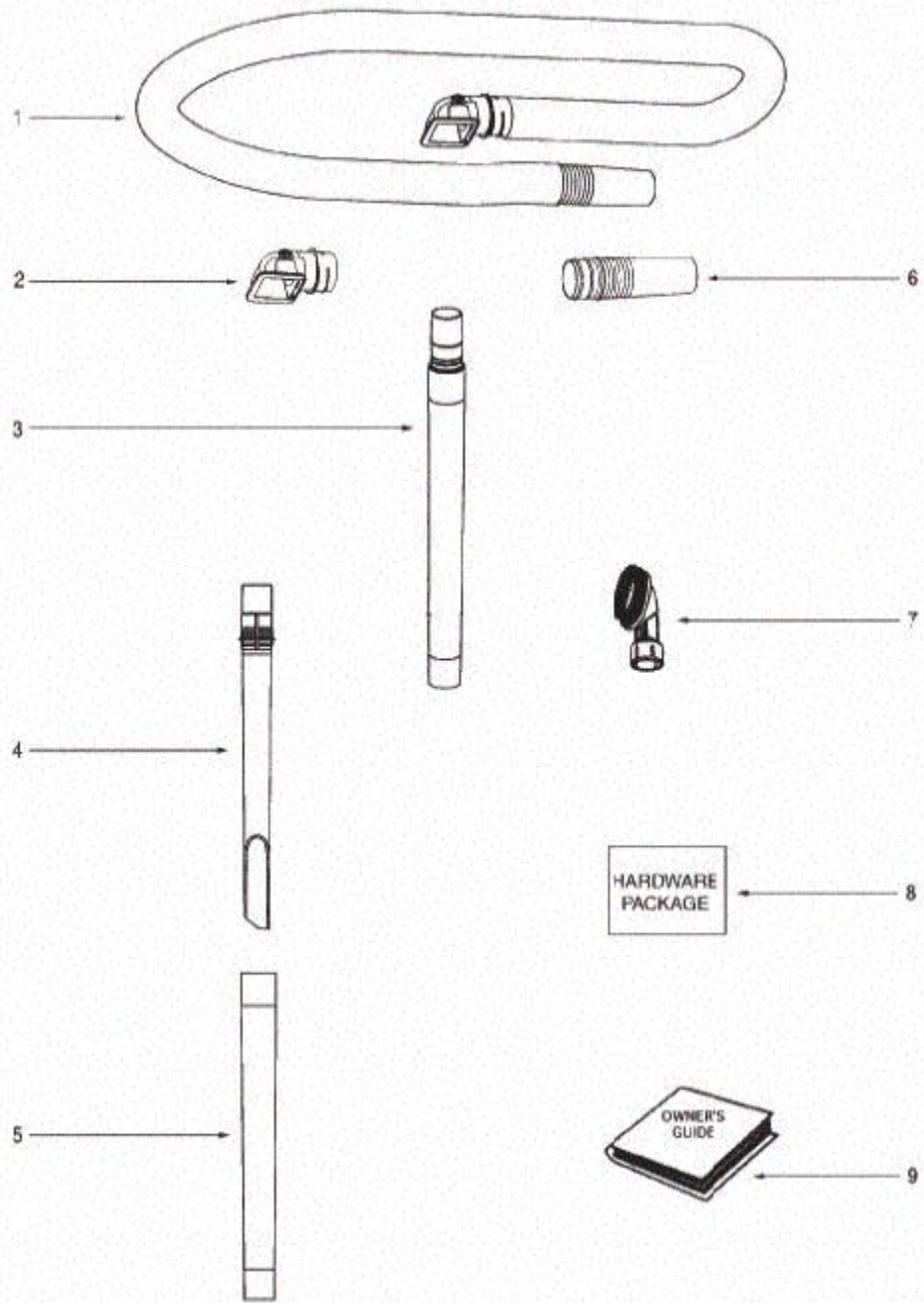

ACCESSORIES - SC5745A

Ref #	Part	Description	Comments	Qty
1	61865-4	HOSE ASSEMBLY - CARTONED	Includes items 2 & 6	
2	71725-313N	ADAPTER - HOSE		
6	70559A-119N	COUPLING - HOSE		
3	77505-22	NESTING WAND ASSEMBLY		
7	60990-2	COMBINATION BRSH BRSTLD-C		
4	77506-355N	WAND - CREVICE		
8	72322	PACKAGE - HARDWARE		
5	77507-119N	WAND - OUTER		
9	83954	OWNERS GUIDE		